



REINTJES AUTOMATION

Gearbox Control System (GBX-C)

Gearbox Automation System (GBX-A)

This document and any data contained herein are subject to modifications or updates at any time and are always non-binding. The data serve informational purposes and cannot be guaranteed in any way. In addition, any data and information will be assessed and determined individually for each project and purpose. This is necessary due to differing characteristics of each project. If this document is delivered in another language than English and in case of divergences of interpretation between the different language texts, the English text shall prevail. Pictures and logos courtesy from all owners of the respective trademarks and rights. Gearbox standard design is dry. All lists only show an extract of gearboxes available. Additional sizes, offset configurations and variations are available on request.

Dimensions and dry weights are approximate and may vary with housing or by input and ratio. Specifications are subject to change without notice. Please contact your REINTJES distributor for current information and binding data.

REINTJES GmbH
Eugen-Reintjes-Straße 7
31785 Hameln
Germany

E-Mail: info@reintjes-gears.de
Phone: +49 5151 1040

www.reintjes-gears.com

Scan here to
download all our
product brochures

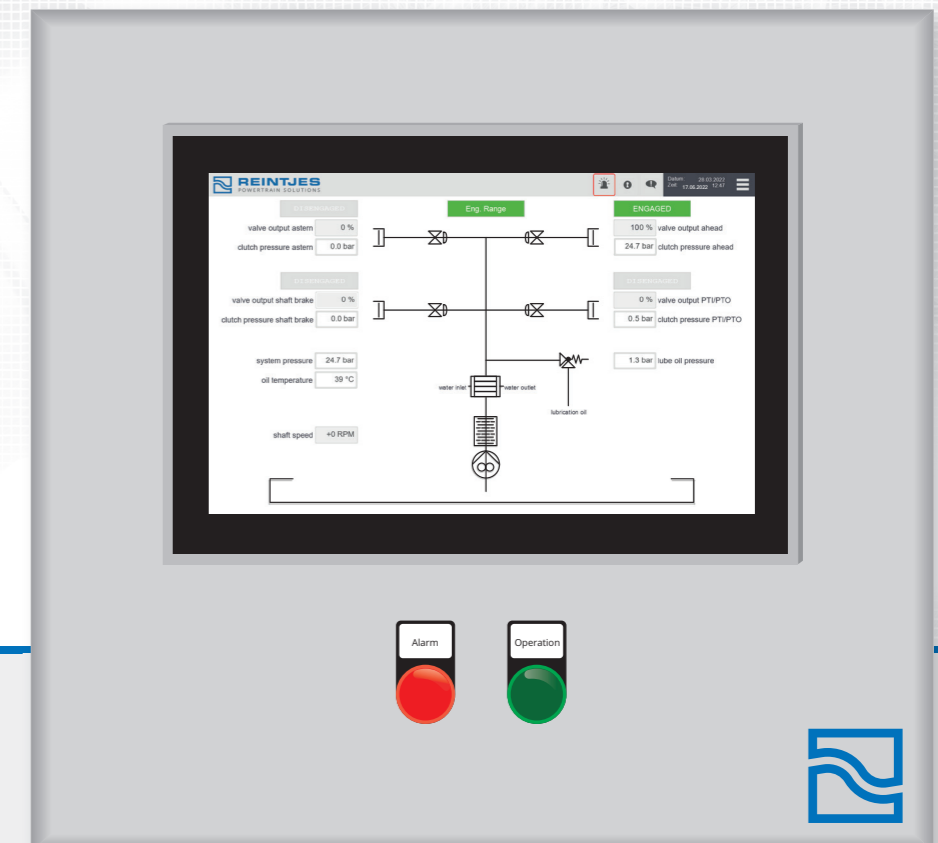

REINTJES AUTOMATION

The innovative REINTJES Automation system is the next step in technological progress in design and execution, developed to achieve a seamless engagement of the gearbox clutches according to customer requirements.

This automation system has been designed as a modular concept that allows combining standard and customised building blocks. The resulting hydraulic control system is tuned exactly to optimise the different functional profiles of the gearbox. This automation system will be installed on new built REINTJES gearboxes or may be retrofitted to REINTJES gearboxes that are already in operation.

The gearbox can be conveniently operated via the vessel control system. This automation system is controlled electronically, allowing an efficient pressure build-up in the gearbox and consequently an optimal operational performance of the disc clutches. As a result, the engagement of the disc clutches is smooth and performed with less hydraulic noise, avoiding an excessive strain on the drive train during engagement. Moreover, this system ensures that different oil temperatures will not affect the engagement behaviour of the gearbox.

Compared to the classic system, the automation system saves a great amount of weight. When installing or operating the gearbox, less overhead space is required above the gearbox, saving valuable space in the engine room.

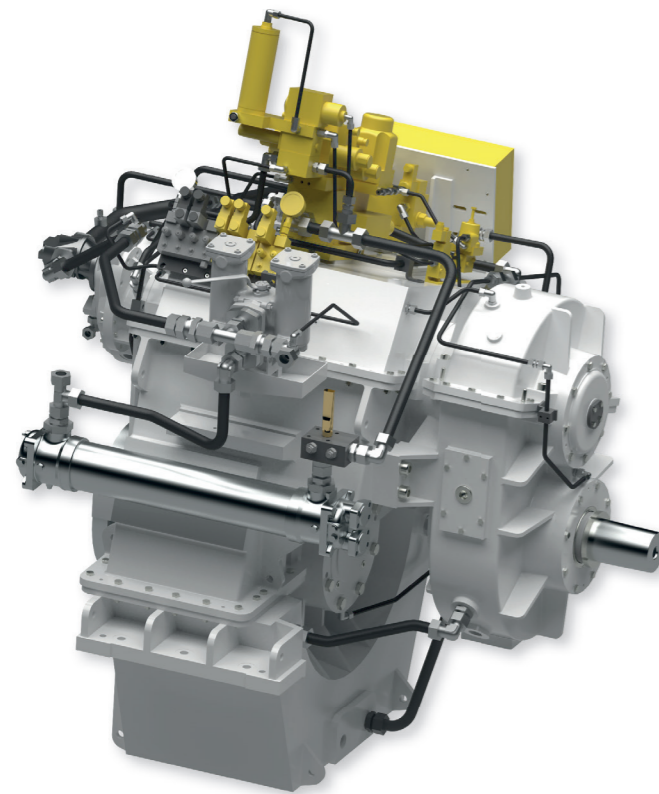

Conventional System

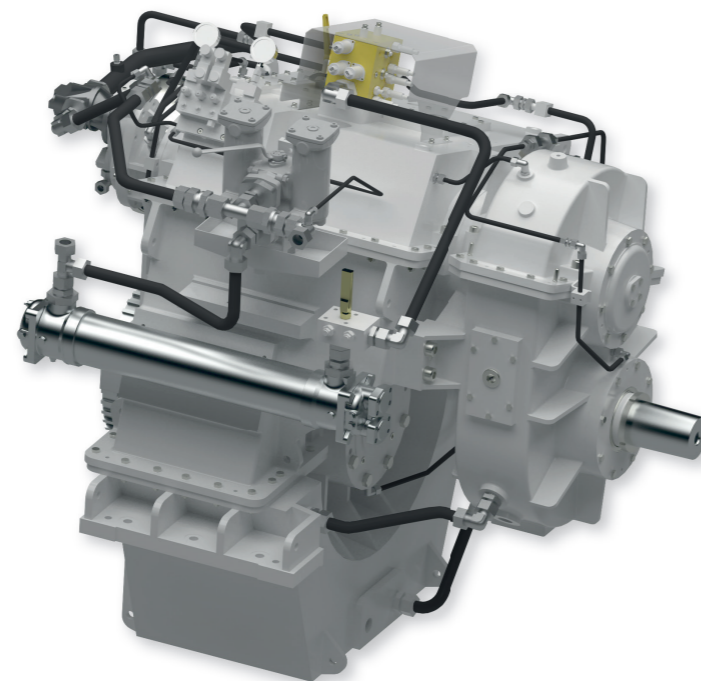

Automation System

GBX-C | Gearbox Control System

For standard applications of reverse reduction gearboxes when changing travelling directions ahead and astern, GBX-C offers the possibility of using a microcontroller with proportional valves to replace the conventional control of the clutches. The gearbox interface does not change.

Feature overview of the new GBX-C control block:

- Proportional valve technology
- Same clutch characteristics in every situation
- Individually adjustable pressure build-up curve

GBX-A | Gearbox Automation System

In addition to the advantages of the GBX-C system, GBX-A uses a PLC (programmable logic controller) to actuate the proportional valves. Each clutch setting can be adjusted individually for the main clutch as well as for additional applications such as engaging the auxiliary drive (PTO / PTI mode). For emergency cases such as crash stop manoeuvres where the vessel needs to be stopped from a high speed within the shortest possible distance a second separate pressure build-up profile for the main clutch can be configured.

The GBX-A system includes a dedicated control cabinet, which can be equipped with a touch screen to view the operational status of the gearbox. The system is standard for gearboxes with options like ADS (trolling function), shaft brake or controllable PTO/PTI that require additional clutch control.

Feature overview of the new GBX-A control block:

- PLC-controlled proportional valves
- Includes hydraulic components and advantages of GBX-C
- Optional HMI (human machine interface) for status information, set up and maintenance
- Easy retrofit of ADS
- Possibility to implement manoeuvre specific clutch behaviour
- Possible interface to any ship control system

